



Max. Gross Machine Weight
Net Machine Weight
Payload
Engine
Rated Power
Struck Capacity
Heaped Capacity (SAE 2:1)

90,000 kg
31,000 kg
59,000 kg
YC6K520-GT30
382 kW
32 m³
38 m³

DW90A MINING TRUCK

DW90A SPECIFICATIONS >>>

ENGINE	
Emission Regulation	Tier 3 / Stage III
Manufacturer	Yuchai
Model	YC6K520-GT30
Rated Power	382 kW (512 hp / 519 ps) @ 1,900 rpm
Peak Torque	2,400 N·m / 1,100-1,500 rpm
Diameter x Stroke	12.939 L
Number of Cylinders	6

TRANSMISSION	
Model	Allison 4800RS
Max. Speed	37 km/h
Retarder Model	Hydraulic Retarder

AXLE	
Front Axle Rated Load	20,000 kg
Rear Axle Rated Load	35,000*2 kg
Suspension Form	Leaf Spring
Total Speed Ratio	18.385
Max. Gradeability	≥30%

BRAKING	
Service Brake	Double Loop
Auxiliary Brake	Engine In-cylinder Brake
Service Braking Gradeability (load)	>25%
Park Braking Gradeability (load)	>15%
Pressure	10 bar
Air Tank Capacity	210 L

STEERING	
Steering System	Full Hydraulic Steering
System Pressure	16 MPa
Turn Radius	≤11,000 mm

HOIST	
Body Lifting Time	≤ 20 s
Body Drop Time	≤ 22 s
System Pressure	22 MPa

CARRIER	
Carriage Size	5,800 mm*3,200 mm*1,750 mm
Rotate Angle	46°
Struck Capacity	32 m ³
Heaped Capacity	38 m ³

TIRE AND RIM	
Drive Type	6x4
Tire Size	1400RS 25 36PR NHS
Rim	10.0/2.0-25

DIMENSIONS	
Overall Length	9,515 mm
Overall Width	3,545 mm
Overall Height	3,900 mm
Loading Height	3,335 mm
Wheel Base	3,800 mm+1,550 mm
Wheel Tread	2,792 mm+2,526 mm
Min. Ground clearance	380 mm
Fuel Tank Capacity	600 L

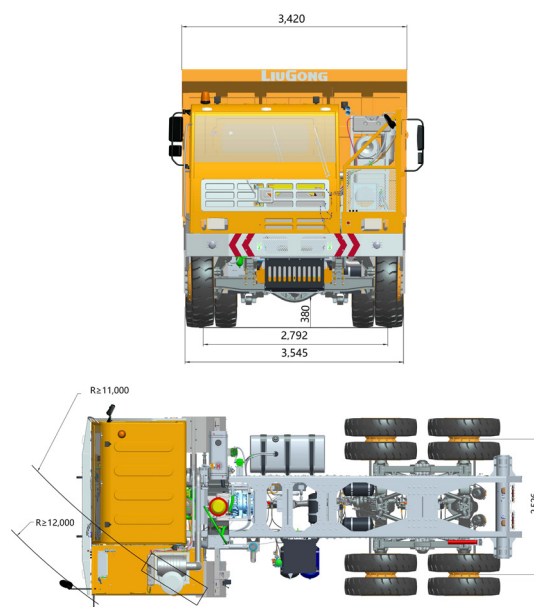
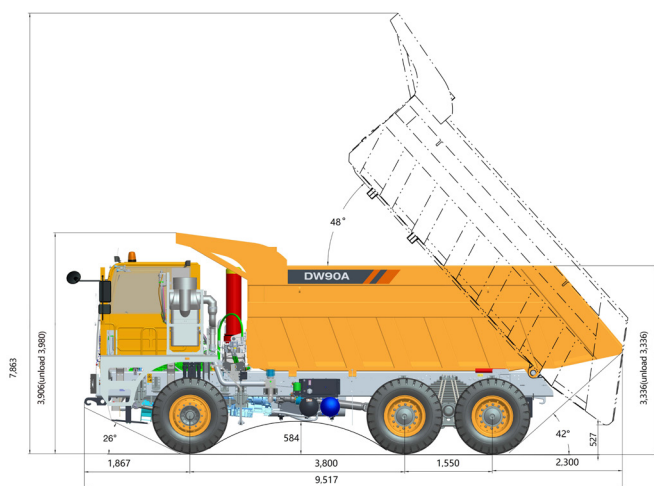

Unit: mm

Guangxi Liugong Machinery Co., Ltd.

No. 1 Liutai Road, Liuzhou, Guangxi 545007, PR China
T: +86 772 3886124 E: overseas@liugong.com
www.liugong.com

Specifications and designs are subject to change without notice. Machines shown may include optional equipment. Liugong standard and optional equipment may vary from region to region. Please consult your Liugong dealer for information specific to your area. Engine power kW is converted to horsepower (1 kW=1.3596 ps and 1 kW=1.3410 hp) in this file.

07/2022 Designed by LiuGong