



<b>Engine</b>	Cummins 6BTAA5.9-C150-II
<b>Rated Power</b>	112 kW (150 hp / 152 ps) @1,950 rpm
<b>Net Power</b>	102 kW (137 hp / 139 ps) @1,950 rpm
<b>Maximum Digging Depth</b>	6,562 mm
<b>Standard Bucket Capacity</b>	1.0 m <sup>3</sup>
<b>Operating Weight</b>	21,500 kg

# 921E EXCAVATOR



# 921E SPECIFICATIONS >>>

## ENGINE

Emission Regulation	Tier 2 / Stage II
Manufacturer	Cummins
Model	6BTAA5.9-C150-II
Rated Power	112 kW (150 hp / 152 ps) @1,950 rpm
Net Power	102 kW (137 hp / 139 ps) @1,950 rpm
Peak Torque	614 N·m@1,500 rpm
Number of Cylinders	6
Displacement	5.9 L

## UNDERCARRIAGE

Shoe Width	600 mm
Number of Shoes per Side	46
Number of Upper Rollers per Side	2
Number of Bottom Rollers per Side	7

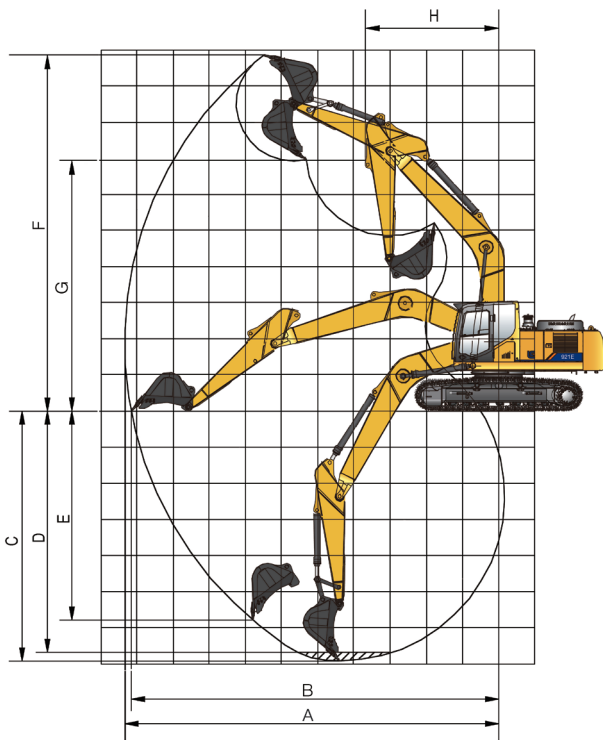

## BOOM & ARM

Boom Length	5,710 mm
Arm Length	2,915 mm

## BUCKET PERFORMANCE

Std. Bucket Heaped Capacity (Referenced)	1.0 m <sup>3</sup>
Min. Heaped Capacity of Bucket Options	0.87 m <sup>3</sup>
Max. Heaped Capacity of Bucket Options	1.2 m <sup>3</sup>

## TRACK DRIVE

Maximum Travel Speed	5.7 km/h
Drawbar Pull	220 kN

## SERVICE CAPACITIES

Fuel Tank	420 L
Engine Oil	25 L
Cooling System	25 L
Hydraulic Reservoir	210 L
Hydraulic System Total	330 L

## HYDRAULIC SYSTEM

Main Pumps Total Flow	448 L/min
Relief Pressure, main	34.3 MPa
Relief Pressure, boost	37.3 MPa

## SWING SYSTEM

Swing Speed	12.5 rpm
-------------	----------

## WORKING RANGE

A. Max. Digging Reach	9,870 mm
B. Max. Digging Reach on Ground	9,685 mm
C. Max. Digging Depth	6,562 mm
D. Max. Digging Depth, 2.44 m (8') level	6,390 mm
E. Max. Vertical Wall Digging Depth	5,080 mm
F. Max. Cutting Height	9,945 mm
G. Max. Dumping Height	7,170 mm
H. Min. Front Swing Radius	3,090 mm
Bucket Digging Force (ISO)	152.5 kN
Arm Digging Force (ISO)	105 kN
Bucket Capacity	1.0 m <sup>3</sup>

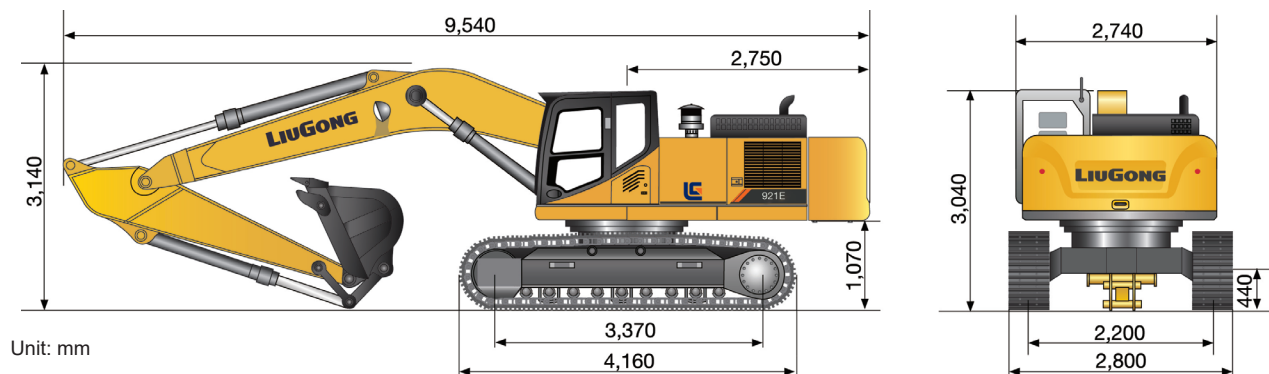

Unit: mm

## Guangxi Liugong Machinery Co., Ltd.

No. 1 Liutai Road, Liuzhou, Guangxi 545007, PR China  
 T: +86 772 3886124 E: overseas@liugong.com  
 www.liugong.com

Specifications and designs are subject to change without notice. Machines shown may include optional equipment. Liugong standard and optional equipment may vary from region to region. Please consult your Liugong dealer for information specific to your area. Engine power kW is converted to horsepower (1 kW=1.3596 ps and 1 kW=1.3410 hp) in this file.

01/2022 Designed by LiuGong  
 Replace the previous versions of 05/2021