



Engine	Cummins 6LT9.3
Gross Power	162 kW (217 hp / 220 ps) @ 2,000 rpm
Net Power	149 kW (200 hp / 202 ps) @ 2,000 rpm
Operating Weight	16,700 kg
Standard Bucket Size	3.0 m ³
Standard Breakout Force	165 kN
Standard Dump Clearance	3,056 mm

855H WHEEL LOADER

855H SPECIFICATIONS >>>

ENGINE

Emission Regulation	Tier 2 / Stage II
Manufacturer	Cummins
Model	6LT9.3
Gross Power	162 kW (217 hp / 220 ps) @ 2,000 rpm
Net Power	149 kW (200 hp / 202 ps) @ 2,000 rpm
Peak Torque	980 N · m
Displacement	9.3 L
Number of Cylinder	6
Aspiration	Turbocharged

TRANSMISSION

Transmission Type	Planetary type, power shift
Torque Converter	Double stage, four elements
Maximum Travel Speed, fwd	40 km/h
Maximum Travel Speed, rev	17 km/h
Number of Speed, fwd	2
Number of Speed, Rev	1

AXLES

Differential Front Type	Conventional
Differential Rear Type	Conventional
Axle Oscillation	±10°

STEERING

Steering Configuration	Articulated
Steering Relief Pressure	16.5 MPa

BRAKES

Service Brake Type	Caliper disc brake
Service Brake Actuation	Air over hydraulic
Parking Brake Type	Flexible shaft control
Parking Brake Actuation	Mechanical

HYDRAULIC SYSTEM

Main Pump Type	Gear
Main Relief Pressure	18 MPa
Raise	5.8 s
Dump Time	1.5 s
Float Down Time	3.0 s
Fastest Total Cycle Time	10.3 s

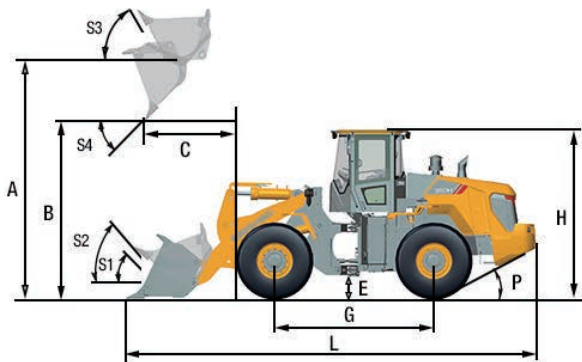

LOADER ARM PERFORMANCE with Standard Bucket 3.0 m³

Tipping Load - Straight (ISO 14397-1:2007)	13,000 kg
Tipping Load - Full Turn (ISO 14397-1:2007)	11,100 kg
Bucket Breakout Force	165 kN
A Maximum Hinge Pin Height	4,114 mm
B Dump Clearance at Full Height Discharge	3,056 mm
C Dump Reach at Full Height Discharge	1,149 mm
D Maximum Digging Depth, Bucket Level	50 mm
S ₁ Bucket Rollback at Ground Level	43°
S ₂ Bucket Rollback at Carry	48°
S ₃ Bucket Rollback at Maximum Height	63°
S ₄ Maximum Dump Angle at Full Height	46°

BUCKET PERFORMANCE

Reference Bucket	2.7 - 5.0 m³
------------------	--------------

DIMENSIONS

E Ground Clearance	431 mm
G Wheelbase	3,250 mm
H Cab Height	3,500 mm
J Wheel Tread	2,150 mm
K Width Over Tires	2,750 mm
L Length with Bucket Down	8,066 mm
M Turn Angle, Either Side	38°
P Rear Angle of Departure	30°
R ₁ Turning Radius, Bucket Carry	6,797 mm
R ₂ Turning Radius, Outside of Tire	6,086 mm
W Width Over Bucket	2,976 mm

TIRES

Tire Size	23.5 - 25
-----------	-----------

OPERATING WEIGHTS

Operating Weight	16,700 kg
------------------	-----------

SERVICE CAPACITY

Fuel Tank	300 L
Engine Oil	22 L
Cooling System	42 L
Hydraulic System	225 L
Transmission and Torque Converter	45 L
Axles, Front/Rear	33 L / 33 L

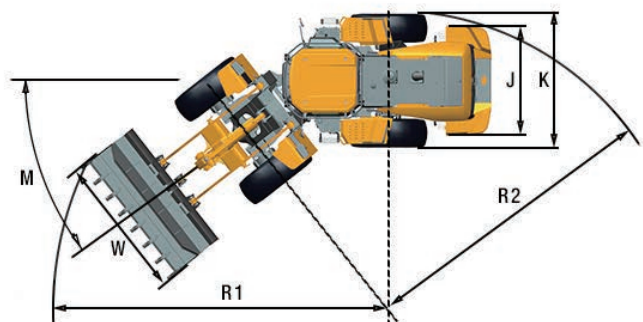

Guangxi Liugong Machinery Co., Ltd.

No. 1 Liutai Road, Liuzhou, Guangxi 545007, PR China
 T: +86 772 3886124 E: overseas@liugong.com
 www.liugong.com

Specifications and designs are subject to change without notice. Machines shown may include optional equipment. LiuGong standard and optional equipment may vary from region to region. Please consult your LiuGong dealer for information specific to your area. Engine power kW is converted to horsepower (1 kW=1.3596 ps and 1 kW=1.3410 hp) in this file.

03/2020 Designed by LiuGong
 Replace the previous versions of 12/2019