



<b>Engine</b>	Yuchai YCF3050-T307
<b>Gross Power</b>	36.5 kW (48.9 hp / 49.6 ps) @ 2,400 rpm
<b>Net Power</b>	32.5 kW (43.5 hp / 44.1 ps) @ 2,400 rpm
<b>Breakout Force</b>	24.5kN
<b>Rated Operating Capacity</b>	795 kg
<b>Bucket Capacity</b>	0.4 m <sup>3</sup>
<b>Operating Weight</b>	2,950 kg

# 355C

## SKID STEER LOADER

# 355C SPECIFICATIONS >>>

## ENGINE

Emission Regulation	Tier 3 / Stage IIIA
Manufacturer	YUCHAI
Model	YCF3050-T307
Gross Power	36.5 kW (48.9 hp / 49.6 ps) @ 2,400 rpm
Net Power	32.5 kW (43.5 hp / 44.1 ps) @ 2,400 rpm
Peak Torque	200N · m @ 1,700 rpm
Number of Cylinders	4
Displacement	2.982L
Cooling Type	Water

## ELECTRICAL SYSTEM

System Voltage	12 V
Alternator Output	100 amps

## CHAIN TANK

Drive Chain Size	80 HS
------------------	-------

## TIRES

Ply Type	Pneumatic
Tire Size	10-16.5
Ply Rating	12

## HYDRAULIC SYSTEM

System Type	Open
Standard Flow	63.8 L/min
Traveling Hydrostatic Pressure	35 MPa
Working Hydrostatic Pressure	21 MPa
Hydraulic Cycle Time, total	7.7s
Raise	3.9 s
Dump	1.9 s
Lower (float down)	1.9 s

## OPERATING WEIGHT

Operating Weight	2,950 kg
------------------	----------

## PERFORMANCE

Static Tipping Load	1,590 kg
Rated Operating Capacity	795 kg
Boom Breakout Force	18.5 kN
Bucket Breakout Force	20.4 kN
Dump Clearance at Full Height Discharge	2,220 mm
Dump Reach at Full Height Discharge	540 mm
Maximum Dump Angle at Full Height	40°
Maximum Hinge Pin Height	2,923 mm
Bucket Rollback at Ground Level	30°
Ground Clearance	204 mm
Angle of Departure	26°
Front Clearance Radius with Bucket	1,800 mm

## SERVICE CAPACITIES

Fuel Tank	100 L
Engine Oil	10 L
Cooling System	13 L
Hydraulic Reservoir	52 L
Hydraulic System Total	70 L
Chain Tanks, Each	8 L

## OPTIONAL ATTACHMENTS

4 in 1 Bucket – 0.4 m <sup>3</sup>	Auger
Rock Bucket – 0.4 m <sup>3</sup>	Snow Blade
Scrap Bucket – 350 to 650 mm	Pick - up Sweeper
Hydraulic Hammer	Hydraulic Shear
Fork	Lift Boom

## STANDARD EQUIPMENT

General Bucket –0.4 m <sup>3</sup>
Control Safety Interlock
Boom Interlock
Quick Coupler
Open ROPS/FOPS Cab

## OPTIONAL EQUIPMENT

Enclosed ROPS/FOPS Cab with AC
Solid Tire
Heater
A/C

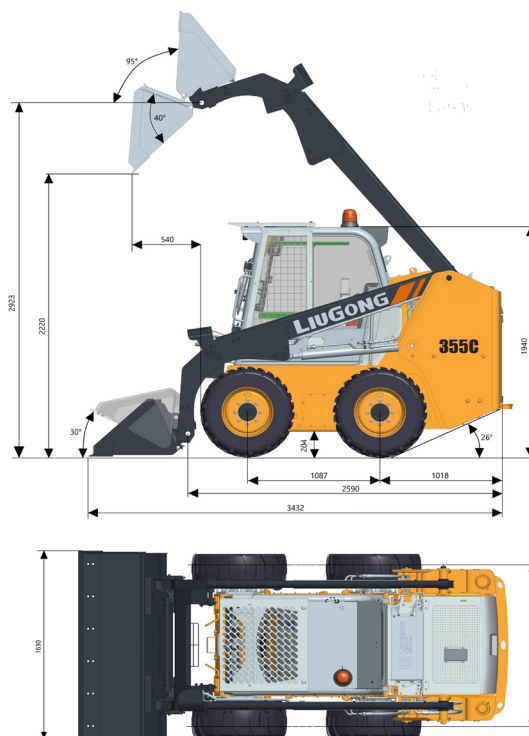

Guangxi Liugong Machinery Co., Ltd.

No. 1 Liutai Road, Liuzhou, Guangxi 545007, PR China  
T: +86 772 3886124 E: overseas@liugong.com  
www.liugong.com

Specifications and designs are subject to change without notice. Machines shown may include optional equipment. Liugong standard and optional equipment may vary from region to region. Please consult your Liugong dealer for information specific to your area. Engine power kW is converted to horsepower (1 kW=1.3596 ps and 1 kW=1.3410 hp) in this file.

05/2024 Designed by LiuGong