



# Swingo 200<sup>+</sup>

Sweeper



The Swingo 200<sup>+</sup> is the ideal solution for daily cleaning jobs on footpaths and cycle paths in inner-city areas, as well as in industrial areas or car parks. Optional attachments enable clearing and spraying in winter maintenance, sink drains, high pressure cleaning and weed control. The Swingo 200<sup>+</sup> enables sustainable and efficient sweeping at low cost over its product life cycle.

## Highlights

- A **2 or 3 broom system** with a pulled suction shaft.
- **Pressurised circulating water system:** conserves resources through water recovery
- **Koanda air circulation system:** operates with almost no particulate matter emission
- Hydrostatic drive with **electric parking brake** and **hill start assistance**
- More than **7,500 machines** are in operation in **40 countries** around the world, developed with over 60 years of experience

## Your benefits

- **High performance:** High suction power even at low diesel engine speeds. The spherical joint of the drawn suction shaft allows movement in all directions and ensures optimum ground hugging and a constant suction power.
- **Unsurpassed comfort:** A spacious cab, excellent visibility, ergonomic controls, an adjustable steering column and a sprung driver's seat with individual adjustment options. AGR („Campaign for Healthy Backs“) tested and recommended.
- **Minimum fine dust emissions:** The Swingo 200<sup>+</sup> meets the best level of PM10/PM2.5 certification with 4 stars each. The combination of the Koanda air circulation system in conjunction with the pressurised circulating water system can reduce fine dust emissions by up to 70%.
- **Flexibility:** Thanks to modular equipment and a wide range of optional expansion options, the sweeper can be adapted to customer-specific requirements.

## Performance features

### Sweeping technology

The Swingo 200+ is available with two independent sweeping systems. A **pushed 2-broom system** with a brush diameter of 850mm or a **pulled 3-broom system** with a brush diameter of 800mm. Both systems can be operated either independently or as a dependent system with convenient controls on the driver's door. The brush speed and the pressure can be infinitely adjusted. The brooms can be chosen between plastic, steel or mixed trimmings, while the suction nozzle can be selected between rollers or runners.

The **2-broom system** with independently controllable circular brushes guarantees absolute mobility in every sweeping situation. Two stable broom arms with integrated buffers allow sweeping widths of up to 2,900mm. Independent broom control is available as an option: separately controllable brooms, up/down, left/right, contact pressure control. This also guarantees clean sweeping results with minimum wear and tear. The broom always returns to its basic position, even when the road conditions change. A version for heavy weed use is also available with additional hydraulic tilting functions for the broom.

The **3-broom system** with freely movable front broom arm offers a wide range of options and a sweeping width of up to 2,600mm. Left-right alignment of the front broom is just as possible as sweeping on two levels or heavy weed broom use. All functions of the front broom are hydraulically controlled, including the broom support pressure. The broom unit under the cabin ensures optimum feed of the sweeping material to the suction shaft, while an overlap is always guaranteed. As an option, the side brushes can also be extended hydraulically and their angle can be adjusted, making it adaptable to any ground conditions during sweeping operations.



### Suction and water system

For the 2-broom system, there is a choice of a basic suction shaft with hydraulically operated coarse dirt flap or an HS suction shaft, which combines the advantages of an integrated coarse dirt flap with optimum air flow. The HS suction shaft guarantees maximum suction power even at low speeds. This can save up to 15% in operating costs.

There is an airflow-optimised suction shaft for the 3-broom system, which does not require a separate coarse dirt flap. Coarse debris can only be easily collected by tilting the suction shaft.

The Swingo 200+ is certified with the best level PM10 4-star and PM2.5. The certificate is considered a quality feature throughout Europe and awards four stars in the PM10 test for the highest level of air pollution control as well as the best possible absorption performance with PM2.5.

With the unique Koanda air circulation system and the combination with the pressurised circulating water system, the emission of harmful fine dust is reduced by up to 70%. A large part of the dust-laden air sucked in remains in the suction system and is returned to the suction mouth in a circuit. The small amount of residual air remaining is cleaned by a fine-pored filter. In addition, the Koanda circulating air system impresses with reduced noise emission, low water consumption and allows sweeping at slightly below-zero temperatures.

The proven pressure circulation water system returns large quantities of circulating water to the circuit by means of a waste water pump for reuse. The water recovery system, with a screen surface of 3.3 m<sup>2</sup> in the container, not only saves fresh water, but also makes optimum use of the container capacity. By filling water into the hopper (up to 250 litres), the operating range can be increased by up to 50%. The collected swept material is both moistened and compacted. The electric fresh water pump supplies the spray nozzles on the circular brooms. The water quantity for the brooms can be conveniently controlled from the cab.



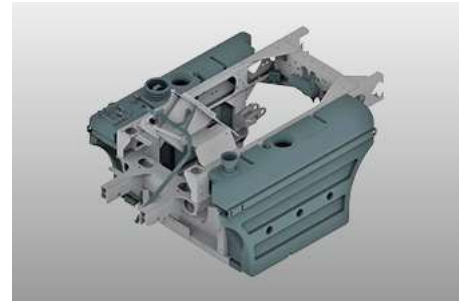
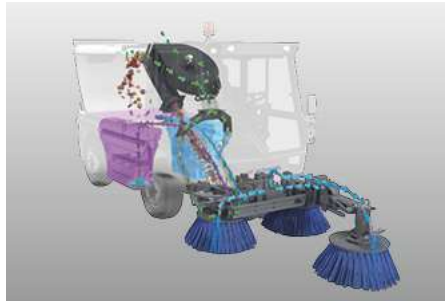

### Sweeping material hopper

The hopper with a system volume of 2m<sup>3</sup> enables maximum sweeping capacity and a large radius of action. The hopper is made of corrosion and seawater resistant aluminium. A large dumping height of 1400mm enables emptying into all common dirt containers. The suction pipe in the hopper is optionally available in wear-resistant stainless steel.

### Ergonomics and comfort

The spacious cabin is equipped with high quality noise and vibration insulation (72 dB(A)). The front windscreen, which extends down to the floor, and the viewing window in the cab floor provide an optimum view of the sweeping unit and suction nozzle. The excellent all-round visibility contributes to a pleasant working environment and thus supports safe operation in road traffic. The standard and powerful air conditioning system creates a pleasant and cool working climate even at high outside temperatures. Fresh air is sucked in and filtered at the rear of the cab, while the cab air filter is designed as a pollen filter.



The sweeping unit is controlled via the door control panel with joysticks and push buttons. With the Auto-Drive option, all sweeping functions and the driving commands in sweeping mode can be conveniently operated via the ergonomically- shaped multifunctional control lever. Driving and sweeping from a single source also means greater safety and less stress. The most important information is visible at a glance on the colour display in the roof console. With the help of the onboard diagnosis system, any faults can be localised quickly and efficiently, while a mechanic can make machine-specific settings on the display.



Smooth steering with a height and angle adjustable steering column, cruise control, minimal pedal forces, a comfortable driver's seat with AGR certificate („Campaign for Healthy Backs“) as well as operating and control instruments in an optimum grip area round off the performance features of a modern, ergonomic workplace.



## Drive

The basic version has a powerful EuroMot 5 engine with 55kW (75hp), which provides high torque and works without additional urea (AdBlue). As an alternative, a Euro 6c engine with 62kW (84hp) is available, with a modern exhaust after-treatment system with diesel oxidation catalytic converter, closed particle filter system, plus urea injection (AdBlue) and SCR catalytic converter. Unique in this machine category is the compact integration of the four-cylinder Euro 6c engine with the same wheelbase as previous versions. The engine and AdBlue tank are perfectly integrated into the chassis so that the manoeuvrability of the Swingo 200+ is not compromised.

Combined with the powerful hydrostatic transmission, this makes driving and working comfortable and economical. The hydrostat with drive on the rear axle is continuously variable with automatic load-dependent control, providing car-like driving and speeds of up to 50km/h. An electric parking brake system with hill start assistance has been integrated into the travel drive since the last development. In the optional Eco mode, the maximum transport speed can be achieved with reduced diesel engine speed, which leads directly to reduced operating costs and emissions.



## Modern vehicle technology

The hot-dip galvanisation of the entire vehicle frame, the suction mouth and important steel components, including the dirt container, provide high-quality corrosion protection.

The hydropneumatically suspended chassis with hydrostatic drive and large 15" wheels offers the highest level of driving comfort in this machine class. The high load capacity and large contact areas of the wheels ensure increased safety with low ground pressure, regardless of road and weather conditions. Optionally, the permissible gross weight can be increased to 5 000 kg. The suspension package, which includes a mechanical option, is perfectly matched to the machine, and ensures safe and comfortable driving just like a car. Good driving comfort, robustness and freedom from maintenance are all optimally combined.

A lowerable running gear (optional) simplifies driving in multi-storey car parks and low entrances. The chassis can be lowered by around 70mm at the push of a button and the system levels itself automatically.

The switchable all-wheel steering makes extremely tight turning manoeuvres possible. The all-wheel steering is monitored by means of steering angle sensors, which enables automatic centring, and is both user-friendly and safe.

A hydraulic dual-circuit brake system with disc brakes on the front and rear axle is fitted as standard.



## Wide range of options

- Koanda air circulation system
- Rear view camera and suction shaft camera
- Weed broom including additional hydraulic tilting functions
- Hand suction hose
- Pressure washer
- Sound insulation package
- Scrub deck
- Sink drawer cleaner
- Automatic central lubrication system
- Auto-Drive (control lever operation)
- Lowerable landing gear
- High quality LED products
- Winter maintenance attachments





### IntelliOPS telematics platform

If you want to monitor, plan, control in real time, optimise or, for example, bill third parties for the activities of your Swingo 200+, then use the digital solutions on our IntelliOPS platform. IntelliOPS supports you in the efficient use of your individual machine as well as in a network with several machines, including those of other brands. Here you can find out more about our digital solutions and how you can use them in a way that is modular and adapted to your needs.

### Gallery





## Variants

### Swingo 200+ | 2-Brush



The 2-broom system with independently controlled circular brushes guarantees absolute mobility in every sweeping situation. Two stable broom arms with integrated buffers allow sweeping widths of up to 2,900 mm.

### Swingo 200+ | 3-Brush



The 3-broom system with freely movable front brush arm offers a sweeping width of up to 2,600 mm. Left-right alignment of the front broom is just as possible as sweeping on two levels or heavy weed broom use.

## Related products

### eSwingo 200+

Sweeper



### Flexigo 150

Sweeper



### Cleango 500

Sweeper



## Keywords

#Counties, Cities & Municipalities #Airports #Contractors #Industry, Construction & Facility Management #Sweeping #Cleaning & Washing #Innecity Roads #Sidewalks & Cycleways #Parking Facilities & Underground Car Parks #Industrial & Port Areas



## Technical data

	Swingo 200+   2-Brush	Swingo 200+   3-Brush
<b>Hopper</b>		
Tank volume	2 m <sup>3</sup>	2 m <sup>3</sup>
Tilt angle	102°	102°
Dumping height tilt discharge	1,400 mm	1,400 mm
<b>Sweeping unit</b>		
Disc brush diameter	850 mm	800 mm
Disc brush speed	120 1/min	100 1/min
Brush material	steel / Plastic / Mixfill	steel / Plastic / Mixfill
Sweeping width	1,400 - 2,900 mm	1,800 - 2,200 mm
Sweeping width with 3rd brush	-	2,600 mm
<b>Suction fan</b>		
Speed	3,300 1/min	3,300 1/min
<b>Water system</b>		
Total water volume	360/380 l	360/380 l
Fresh water volume	190 l	190 l
Water spray system	3 bar / 11 l/min	3 bar / 11 l/min
<b>Drive system - auxiliary engine</b>		
Engine type	VM R754	VM R754
Number of cylinders	4	4
Exhaust emission	EuroMot V	EuroMot V
After treatment system	DOC + DPF	DOC + DPF
Fuel	Diesel	Diesel
Displacement	2,970 cm <sup>3</sup>	2,970 cm <sup>3</sup>
Performance	55 kW (75 PS) @ 2,300 1/min	55 kW (75 PS) @ 2,300 1/min
Torque	310 Nm	310 Nm
<b>Drive system - auxiliary engine 2</b>		
Engine type	VM R754	VM R754
Number of cylinders	4	4
Exhaust emission	Euro 6c	Euro 6c
After treatment system	AdBlue + SCR-Kat	AdBlue + SCR-Kat
Fuel	Diesel	Diesel
Displacement	2,970 cm <sup>3</sup>	2,970 cm <sup>3</sup>
Performance	62 kW (84 PS) @ 2,300 1/min	62 kW (84 PS) @ 2,300 1/min
Torque	270 Nm	270 Nm
<b>Steering</b>		
Steering angle front axle	48°	48°
Steering angle rear axle	24°	24°
Ø Turning circle wall/wall (2-wheel st.)	8,400 mm	8,300 mm
Ø Turning circle kerb/kerb (2-wheel st.)	6,350 mm	6,350 mm
Ø Turning circle wall/wall (4-wheel st.)	7,100 mm	6,800 mm
Ø Turning circle kerb/kerb (4-wheel st.)	4,750 mm	4,750 mm
<b>Tires</b>		
Standard front tire size	225/70 R15	225/70 R15
Standard rear tire size	225/70 R15	225/70 R15
<b>Speed</b>		
Transport speed	25 km/h / 40 km/h / 45 km/h / 50 km/h	25 km/h / 40 km/h / 45 km/h / 50 km/h
Sweeping speed permanent use	12 km/h	12 km/h
<b>Dimensions</b>		
Length without 3rd brush	-	4,090 mm
Length with brush	4,580 mm	-
Length with 3rd brush	-	5,090 mm
Width without brush	1,300 mm	1,300 mm
Height (without beacon)	1,990 mm	1,990 mm
Wheelbase	1,820 mm	1,820 mm
Track width front	1,073 mm	1,073 mm
Track width rear	1,073 mm	1,073 mm
<b>Weights</b>		

	<b>Swingo 200+   2-Brush</b>	<b>Swingo 200+   3-Brush</b>
Empty weight of the basic unit approx.	2,900 kg	3,000 kg
Permitted total weight	4,500 / 5,000 kg	4,500 / 5,000 kg



[www.aebi-schmidt.com](http://www.aebi-schmidt.com)  
 © Aebi Schmidt Group  
 Aebi Schmidt Holding AG  
 CH-8050 Zurich

All rights reserved. Technical data is subject to change. Illustrations are not binding. Errors and amendments excepted.

Document created on 28.09.2022

